

STEP BY STEP INSTRUCTIONS ON THE
PROSTHETIC PROCEDURES



Straumann® Anatomic IPS e.max® Abutment



The ITI (International Team for Implantology) is academic partner of Institut Straumann in the areas of research and education.

CONTENT

Straumann® Anatomic IPS e.max®1 Abutment	2
1. Cement-retained crowns and bridges	3
1.1 Straumann® Anatomic IPS e.max®1 Abutment – Lab procedure	3
1.2 Straumann® Anatomic IPS e.max®1 Abutment – Prosthetic procedure	7
1.3 Straumann® Anatomic IPS e.max®1 Abutment – Chairside procedure for temporary restorations	8
2. Screw-retained crowns, directly veneered	13
2.1 Straumann® Anatomic IPS e.max®1 Abutment – Lab procedure	13
2.2 Straumann® Anatomic IPS e.max®1 Abutment – Prosthetic procedure	18
3. Screw-retained crowns using the press-on technique	19
3.1 Straumann® Anatomic IPS e.max®1 Abutment – Lab procedure	19
3.2 Straumann® Anatomic IPS e.max®1 Abutment – Prosthetic procedure	27
Important guidelines	28

STRAUMANN® ANATOMIC IPS E.MAX®¹ ABUTMENT

Intended use

- Cement-retained crowns and bridges via mesostructure
 - Conventional procedure
 - Temporary restoration chairside
- Screw-retained crowns
 - Direct veneering (with IPS e.max® Ceram¹)
 - Press-on technique (with IPS e.max® ZirPress¹)

Material

- Zirconium dioxide

Characteristics

Simple

- Processing of a highly esthetic ceramic abutment in different colors with conventional lab methods
- Less grinding necessary due to prepared mucosa margins
- Adaptation to natural soft tissue contour due to prepared mucosa margins in different heights
- Oval shape resembles emergence profile of a natural tooth

Reliable

- Biocompatible and low thermal conductivity
- High-performance all-ceramics thanks to a high strength and high fracture toughness
- Reduced risk of margins shining through the soft tissue even with thin mucosa biotype
- CrossFit™ Connection
- Precise fit

Note

Use a new basal screw for the final insertion of the abutment.



1. CEMENT-RETAINED CROWNS AND BRIDGES

Cement-retained restorations need to fulfill the following criteria (see 2c):

- Individualized abutments must have cusp and marginal ridge support.
- The maximum thickness of the veneering material on top of the coping must not exceed a maximum of 2.0 mm in all directions.
- Avoid any sharp edges.

1.1 Straumann® Anatomic IPS e.max®¹ Abutment – Lab procedure

The following case describes the fabrication of a cement-retained crown by using the Straumann® Anatomic IPS e.max®¹ Abutment.



Step 1 – Fabricating the master cast and wax-up

- Fabricate the master cast including a gingival mask with the corresponding implant analog (see instructions in chapter 5 in brochure Art. No. 152.810).



- For optimal esthetic planning, design a full anatomical wax-up.



- Make a silicone key over the full wax-up in order to define the optimal shape of the modified abutment.

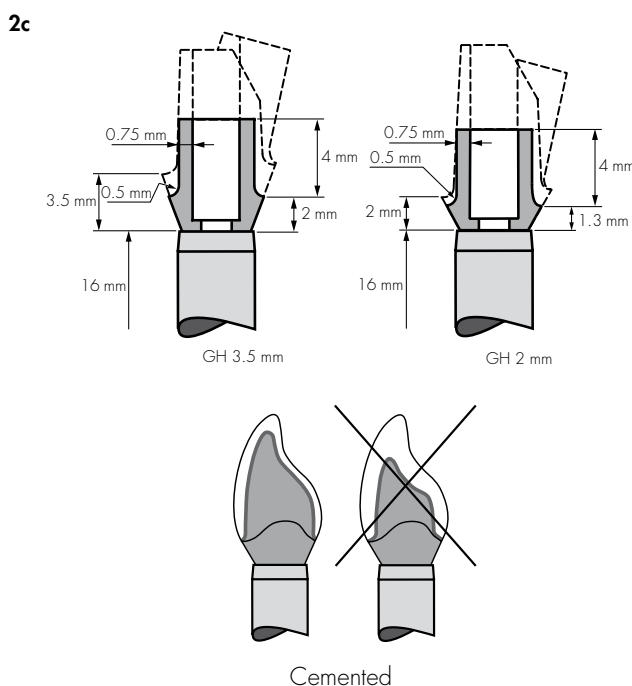

Step 2 – Preparing the Straumann® Anatomic IPS e.max® Abutment

- Place the abutment on the polishing aid / analog and hand tighten the screw using the SCS screwdriver.
- For the individualization of the Straumann® Anatomic IPS e.max® Abutment, it is recommended to work with a water-cooled turbine and abrasive instruments that are appropriate for grinding sintered ZrO_2 material. Work with a low grinding pressure and avoid any spark formation. The Ivoclar Vivadent grinding instrument recommendations for IPS e.max® must be followed.

Note

In order to keep sufficient stability of the abutment, **do not deviate** from the dimensions shown in the following graphics (2c). The height of the abutment must achieve at least 65 % of the complete restoration.

- The final geometry of the abutment has to meet the requirements of the material of the final restoration.

2d



- After grinding and/or polishing the abutment a regeneration firing has to be conducted in a firing furnace: 65 °C (117 °F) per minute heating up to 1050 °C (1922 °F)/ 15 minutes holding time and long term cooling down with 25 °C (45 °F) per minute to 750 °C (1382 °F).

3a



Step 3 – Fabricating the superstructure

- Use a standard procedure to fabricate the ceramic coping with the etkon™ es1 scanner and the etkon™_visual software.

3b

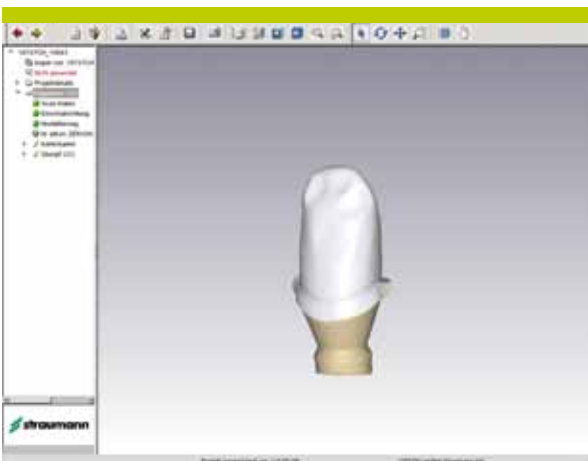



- Veneer the coping with conventional veneering material synchronized to the thermal expansion coefficient of the ceramic coping.
- Coefficient of thermal expansion² (CTE) (100–500 °C)
 $10.80 \pm 0.25 \text{ } 10^{-6} \text{ K}^{-1}$
- For veneering follow the recommendations of the ceramic material manufacturer.

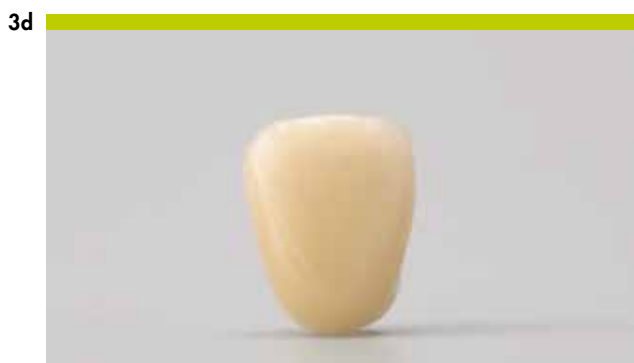

 **Note**

In case of adhesive bonding, sandblast the portions of the abutment surface which will be covered with cement with Al_2O_3 (type 100 microns) at 0.5–1.0 bar (15–30 psi). While sandblasting, the implant configuration must be protected with the polishing aid.

1.2 Straumann® Anatomic IPS e.max®1 Abutment – Prosthetic procedure

The final restoration is delivered to the doctor's office on the master cast.

Step 1 – Preparation

- Remove the healing cap or temporary restoration.
- Remove the superstructure from the master cast and unscrew the abutment from the analog.
- Clean and dry the interior of the implant and the abutment thoroughly.
- Prepare the surface of the abutment corresponding to the cementation material which will be used (e.g. in case of adhesive bonding apply primer).
- Condition the inner surface of the superstructure according to the instructions for use given by the according manufacturer (e.g. in case of adhesive bonding apply primer).



Step 2 – Final Insertion

- Position the cleaned abutment in the implant. Tighten the screw to 35 Ncm using the SCS screwdriver along with the ratchet and the torque control device (see instructions in chapter 7.5 in brochure Art. No. 152.810).
- Close the SCS screw channel with cotton and sealing compound (i.e. gutta-percha). This allows for later removal of the modified abutment in the event a restoration replacement is required.
- Cement the superstructure onto the abutment.
- Remove excess of the cement.

Note

Use a new basal screw for the final insertion of the abutment.

1.3 Straumann® Anatomic IPS e.max® Abutment – Chairside procedure for temporary restorations

The following case describes the usage of the Straumann® Anatomic IPS e.max® Abutment chairside.



Step 1 – Preparing the Straumann® Anatomic IPS e.max® Abutment

- For the individualization of the Straumann® Anatomic IPS e.max® Abutment, it is recommended to work with a water-cooled turbine and abrasive instruments that are appropriate for grinding sintered ZrO₂ material. Work with a low grinding pressure and avoid any spark formation. The Ivoclar Vivadent grinding instrument recommendations for IPS e.max® must be followed.

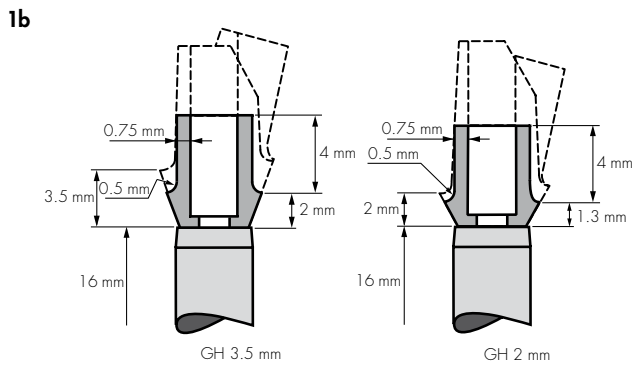

Note

In order to keep sufficient stability of the abutment, **do not deviate** from the dimensions shown in the following graphics (1b). The height of the abutment must achieve at least 65 % of the complete restoration.

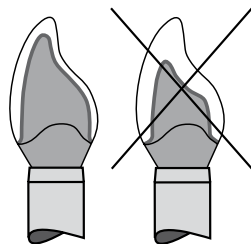

Cemented

- The final geometry of the abutment has to meet the requirements of the framework and veneering material.



- After grinding and/or polishing the abutment a regeneration firing has to be conducted in a firing furnace: 65 °C (117 °F) per minute heating up to 1050 °C (1922 °F)/ 15 minutes holding time and long term cooling down with 25 °C (45 °F) per minute to 750 °C (1382 °F).



Step 2 – Fabricating the cement-retained temporary single crown

- Use a standard procedure to fabricate the cement-retained single crown (e.g. grind out a prefabricated plastic tooth).

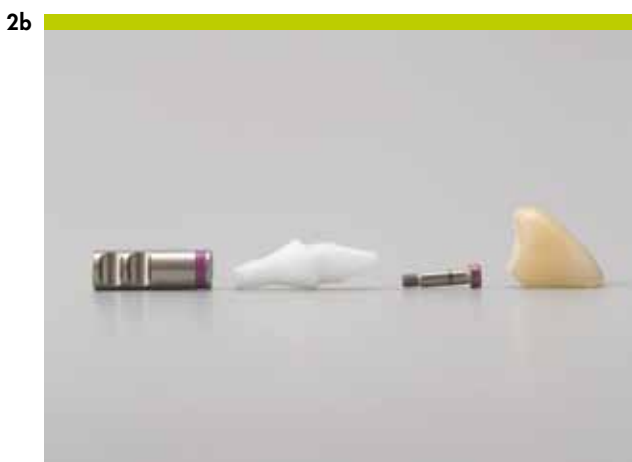

3a



Step 3 – Placing the modified Straumann® Anatomic IPS e.max®1 Abutment

- Place the abutment on the implant and tighten the screw with a torque between 15 Ncm and 35 Ncm using the SCS screwdriver along with the ratchet and the torque control device (see instructions in chapter 7.5 in brochure Art. No. 152.810).

3b



Note

Before taking the abutment level impression the abutment needs to be torqued with 35 Ncm.

- Cover the screw head with absorbent cotton or gutta-percha and seal the screw channel temporarily (e.g. with absorbent cotton).

3c



- Take an impression with an individualized impression tray and order the final restoration.

4



Step 4 – Cementing the temporary single crown

- Coat the internal configuration of the crown with temporary cement and cement it onto the Straumann® Anatomic IPS e.max®¹ Abutment.
- Remove excess of the cement.



Step 5 – Final insertion

- Remove the temporary restoration.
- Remove the superstructure from the master cast and unscrew the abutment from the analog.
- Clean and dry the interior of the abutment thoroughly.
- Close the SCS screw channel with cotton and sealing compound (i.e. gutta-percha). This allows for later removal of the modified abutment in the event a restoration replacement is required.

2. SCREW-RETAINED CROWNS, DIRECTLY VENEERED

Screw-retained restorations need to fulfill the following criteria (see 2c):

- In the anterior region, screw hole access must be located in the palatal/lingual area of the restoration.
- The screw hole position in the incisal or labial area is contraindicated.
- In the posterior area, screw hole position must be located in the center of the occlusal area of the restoration.
- Before veneering or press-on procedure the individualized abutment must have an anatomic tooth supported design, means cusp and marginal ridge support.
- Individualized abutments must have cusp and marginal ridge support.
- The maximum thickness of the veneering material on top of the individualized abutments (layering ceramic and/or press-on ceramic) must not exceed a maximum of 2.0 mm in all directions of the screw retained restoration.

2.1 Straumann® Anatomic IPS e.max®¹ Abutment – Lab procedure

The following case describes the fabrication of screw-retained crowns directly veneered, when using the Straumann® Anatomic IPS e.max®¹ Abutment and IPS e.max® Ceram¹.



Step 1 – Fabricating the master cast and wax-up

- Fabricate the master cast including a gingival mask with the corresponding implant analog (see instructions in chapter 5 in brochure Art. No. 152.810).



- For optimal esthetic planning, design a full anatomical wax-up.



- Make a silicone key over the full wax-up in order to define the optimal shape of the modified abutment.

2a



Step 2 – Preparing the Straumann® Anatomic IPS e.max® Abutment

- Place the abutment on the polishing aid / analog and hand tighten the screw using the SCS screwdriver.

2b



- For the individualization of the Straumann® Anatomic IPS e.max® Abutment, it is recommended to work with a water-cooled turbine and abrasive instruments that are appropriate for grinding sintered ZrO_2 material. Work with a low grinding pressure and avoid any spark formation. The Ivoclar Vivadent grinding instrument recommendations for IPS e.max® must be followed.

2c

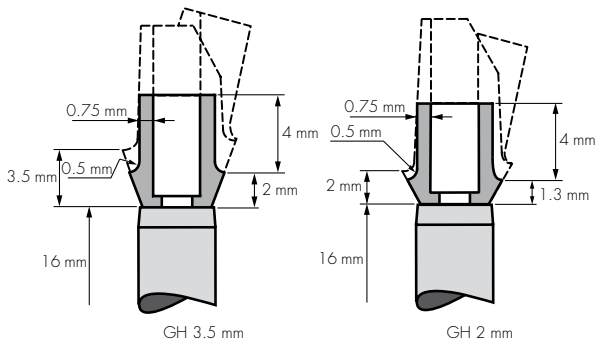

Note

In order to keep sufficient stability of the abutment, **do not deviate** from the dimensions shown in the following graphics (2c). The height of the abutment must achieve at least 65 % of the complete restoration.

- The final geometry of the abutment has to meet the requirements of the veneering material.

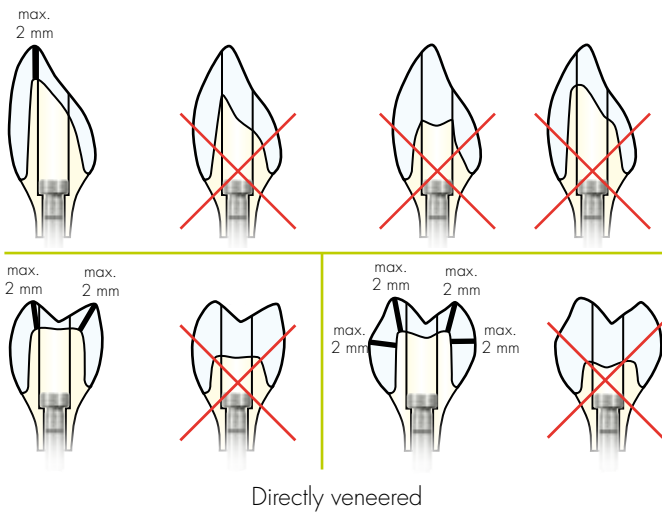

2d



- After grinding and/or polishing the abutment a regeneration firing has to be conducted in a firing furnace: 65 °C (117 °F) per minute heating up to 1050 °C (1922 °F)/ 15 minutes holding time and long term cooling down with 25 °C (45 °F) per minute to 750 °C (1382 °F).

3a

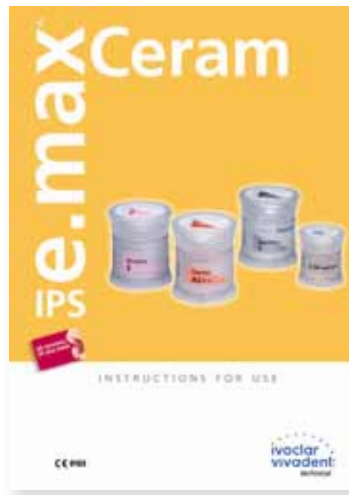

3b



Step 3 – Veneering

- For the veneering of the Straumann® Anatomic IPS e.max®¹ Abutment, use conventional veneering material synchronized to the thermal expansion coefficient of the abutment.
- Coefficient of thermal expansion² (CTE) (100–500 °C)
 $10.80 \pm 0.25 \cdot 10^{-6} \text{K}^{-1}$
- In this case IPS e.max® Ceram¹ has been used. For further details please consult the brochure “Instructions for use IPS e.max® Ceram¹” (www.ivoclarvivadent.com).
- Steam clean the abutment and apply the IPS e.max® Ceram ZirLiner¹ only where IPS e.max® Ceram¹ will be applied later on.
- The implant configuration must be protected with the polishing aid while applying the IPS e.max® Ceram ZirLiner¹.

Note

Do not sandblast the abutment before applying the IPS e.max® Ceram Liner¹. Avoid any application of IPS e.max® Ceram ZirLiner¹ into the screw channel.

3c



- Particular attention must be given to an even layer thickness of the porcelain veneered on the abutment.

 **Note**

Observe the maximum thickness of the layering ceramic material (max. 2 mm).

3d



3e



2.2 Straumann® Anatomic IPS e.max®¹ Abutment – Prosthetic procedure

The final restoration is delivered to the doctor's office on the master cast.

Step 1 – Preparation

- Remove the healing cap or temporary restoration.
- Remove the veneered abutment from the master cast.
- Clean and dry the interior of the implant and the abutment thoroughly.

Step 2 – Final insertion

- Position the cleaned and veneered abutment in the implant. Tighten the screw to 35 Ncm using the SCS screwdriver along with the ratchet and the torque control device (see instruction in chapter 7.5, in brochure Art. No. 152.810).



- Close the SCS screw channel with cotton and sealing compound (i.e. gutta-percha). This allows for later removal of the modified abutment in the event a restoration replacement is required.

Note

Use a new basal screw for the final insertion of the abutment.

3. SCREW-RETAINED CROWNS USING THE PRESS-ON TECHNIQUE

Screw-retained restorations need to fulfill the following criteria (see 2c):

- In the anterior region, screw hole access must be located in the palatal/lingual area of the restoration.
- The screw hole position in the incisal or labial area is contraindicated.
- In the posterior area, screw hole position must be located in the center of the occlusal area of the restoration.
- Before veneering or press-on procedure the individualized abutment must have an anatomic tooth supported design, means cusp and marginal ridge support.
- Individualized abutments must have cusp and marginal ridge support.
- The maximum thickness of the veneering material on top of the individualized abutments (layering ceramic and/or press-on ceramic) must not exceed a maximum of 2.0 mm in all directions of the screw retained restoration.

3.1 Straumann® Anatomic IPS e.max®¹ Abutment – Lab procedure

The following case describes the fabrication of a screw-retained crown when using the Straumann® Anatomic IPS e.max®¹ Abutment in combination with the press-on technique. In this case IPS e.max® ZirPress¹ has been used.



Step 1 – Fabricating the master cast and wax-up

- Fabricate the master cast including a gingival mask with the corresponding implant analog (see instructions in chapter 5 in brochure Art. No. 152.810).



- For optimal esthetic planning, design a full anatomical wax-up.



- Make a silicone key over the full wax-up in order to define the optimal shape of the modified abutment.

2a



Step 2 – Preparing the Straumann® Anatomic IPS e.max® Abutment

- Place the abutment on the polishing aid / analog and hand tighten the screw using the SCS screwdriver.

2b



- For the individualization of the Straumann® Anatomic IPS e.max® Abutment, it is recommended to work with a water-cooled turbine and abrasive instruments that are appropriate for grinding sintered ZrO_2 material. Work with a low grinding pressure and avoid any spark formation. The Ivoclar Vivadent grinding instrument recommendations for IPS e.max® must be followed.

2c

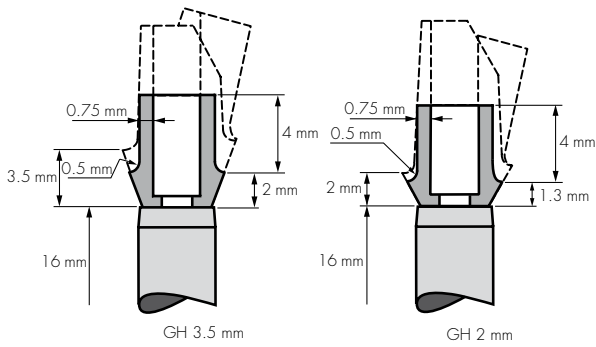

Note

In order to keep sufficient stability of the abutment, **do not deviate** from the dimensions shown in the following graphics (2c). The height of the abutment must achieve at least 65 % of the complete restoration.

- The final geometry of the abutment has to meet the requirements of the framework and veneering material.

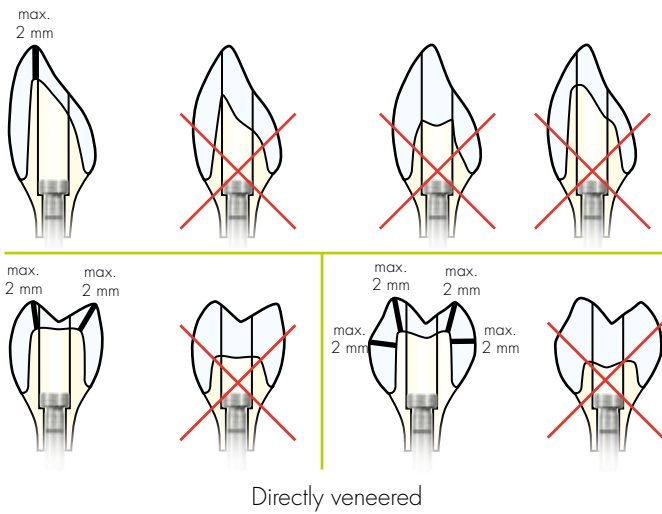

2d



- After grinding and/or polishing the abutment a regeneration firing has to be conducted in a firing furnace: 65 °C (117 °F) per minute heating up to 1050 °C (1922 °F)/ 15 minutes holding time and long term cooling down with 25 °C (45 °F) per minute to 750 °C (1382 °F).

3a

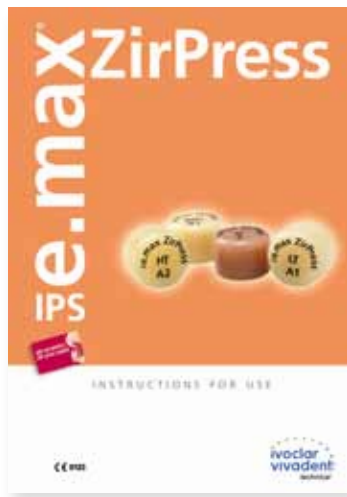

3b



Step 3 – Process of press-on technique

- For pressing onto the Straumann® Anatomic IPS e.max®¹ Abutment, use conventional press-on material synchronized to the thermal expansion coefficient of the abutment.
- Coefficient of thermal expansion² (CTE) (100–500 °C)
 $10.80 \pm 0.25 \cdot 10^{-6} \text{K}^{-1}$
- In this case IPS e.max® ZirPress¹ has been used. For further details please consult the brochure "Instructions for use IPS e.max® ZirPress¹" (www.ivoclarvivadent.com).
- Steam clean the abutment and apply the IPS e.max® Ceram ZirLiner¹ only where IPS e.max® ZirPress¹ will be applied later on.
- The implant configuration must be protected with the polishing aid while applying the IPS e.max® Ceram ZirLiner¹.

Note

Do not sandblast the abutment before applying the IPS e.max® Ceram Liner¹. Avoid any application of IPS e.max® Ceram ZirLiner¹ into the screw channel.



- Observe the respective material thickness (minimum 0.7 mm up to 2 mm) in order to ensure a proper press-on restoration.



 **Note**

In order to prevent IPS e.max® ZirPress¹ to intrude into the screw channel of the abutment do not cover the screw channel with wax.



- Sprueing



- Cover the whole abutment with investment material and ensure that the screw channel is also completely filled.



- Before pressing, ensure that the pressing furnace is sufficiently preheated.



- The implant configuration must be protected with the polishing aid (e. g. sandblasting).



3j



3k



3l



Note

The long term success of the prosthetic work depends on the accurate fit of the restoration. Therefore the following recommendations must be observed:

- Allow for enough cooling time of the press-on abutment before divestment
- Rough divestment is carried out with glass polishing beads at 4 bar (60 psi) pressure
- Fine divestment is carried out with glass polishing beads at 2 bar (30 psi) pressure
- Do not use Al_2O_3 for rough or fine divestment
- Do not sandblast the conical portion of the abutment and always protect the implant/abutment interface with the polishing aid

■ Immerse the pressed objects into the IPS e.max® Press Invex Liquid (min. 5 minutes, max. 10 minutes) and ensure that they are completely covered.

■ Carefully remove the white reaction layer on the pressed objects with Al_2O_3 (type 100 microns) at 1 – 2 bar (15 – 30 psi) pressure.

3m



- Veneer, shade and glaze the restoration according to the individual situation.

 **Note**

The implant configuration must be protected with the polishing aid while applying the IPS e.max® Ceram¹.

3n



- Final restoration

3.2 Straumann® Anatomic IPS e.max®1 Abutment – Prosthetic procedure

The final restoration is delivered to the doctor's office on the master cast.

Step 1 – Preparation

- Remove the healing cap or temporary restoration.
- Remove the overpressed abutment from the master cast.
- Clean and dry the interior of the implant and the abutment thoroughly.



Step 2 – Final insertion

- Position the cleaned abutment in the implant. Tighten the screw to 35 Ncm using the SCS screwdriver along with the ratchet and the torque control device (see instructions in chapter 7.5 in brochure Art. No. 152.810).



- Close the SCS screw channel with cotton and sealing compound (i. e. gutta-percha). This allows a later removal of the modified abutment in the event a restoration replacement is required.

IMPORTANT GUIDELINES

Disclaimer of liability

The Straumann® dental implants and other Straumann products are part of an overall concept and may be used only in conjunction with the corresponding original components and instruments according to Institut Straumann AG's instructions and recommendations.

The use of third-party components not distributed directly or indirectly by Institut Straumann AG in conjunction with the Straumann® Dental Implant System voids any guarantee and/or warranty from Institut Straumann AG and from the contractual partners of the Straumann® Dental Implant System.

Instructions as to the application of our products take place verbally, in writing, by electronic media or in hands-on trainings corresponding to the state of the art at the time of introduction of the product.

The user of Straumann products is responsible for determining whether or not any product is suitable for a particular patient and circumstances. Straumann disclaims any liability, expressed or implied, and bears no responsibility for any direct, indirect, punitive or other damages, arising out of or in connection with any errors in professional judgment or practice in the use or installation of Straumann products.

The user is also obliged to study the latest developments of the Straumann® Dental Implant System and their applications regularly.

Please note

The descriptions contained in this document are not sufficient for immediate use of the Straumann® Dental Implant System. Knowledge of dental implantology and instruction in the handling of the Straumann® Dental Implant System provided by an operator with the relevant experience are always necessary.

Availability

Some of the products listed in this brochure are not available in all countries.

Validity

Upon publication of this brochure, all previous versions are superseded.

Caution

In addition to the caution notes in this basic information, our products must be secured against aspiration when used intraorally. Do not use damaged or blunt instruments.

Units per package

Unless stated otherwise, there is one unit in each package.

Documentation

For detailed instructions on the Straumann® Dental Implant System contact your Straumann representative.

Copyright and trademarks

Straumann documents may not be reprinted or published, in whole or part, without the written authorization of Institut Straumann AG. Straumann® and/or other products and logos from Straumann® that are mentioned here are trademarks or registered trademarks of Straumann Holding AG and/or its affiliates.













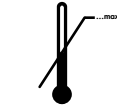

Definition SLActive®

Sand-blasted, large grit, Acid-etched, chemically active and hydrophilic

Definition SLA®

Sand-blasted, Large grit, Acid-etched

Explanation of the symbols on labels and instruction leaflets

	Batch code
	Catalog number
	Sterilized using irradiation
	Lower limit of temperature
	Upper limit of temperature
	Temperature limitation
Rx only	Caution: U.S. Federal law restricts this device to sale by or on the order of a licensed dentist.
	Do not re-use
	Non-sterile
	Caution, consult accompanying documents
	Use by
	Keep away from sunlight
	Straumann Products with the CE mark fulfill the requirements of the Medical Devices Directive 93/42 EEC
	
	Consult operating instructions

Colored warning labels

YELLOW = CAUTION	Indicates hazards or unsafe handling which might cause minor injury or damage to property
ORANGE = WARNING	Indicates hazards which might cause serious or fatal injury
RED = DANGER	Indicates hazards which might cause immediate serious or fatal injury

Straumann® Anatomic IPS e.max®¹ Abutment is available in the following range of opacity:
MO 0 and MO 1 (MO = Medium Opacity)

¹ IPS e.max®, IPS e.max® Ceram, IPS e.max® ZirPress, IPS e.max® Ceram ZirLiner, IPS e.max® Ceram Liner
are registered trademarks of Ivoclar Vivadent, Liechtenstein

² Ivoclar Vivadent, Liechtenstein

www.straumann.com



STRAUMANN GUARANTEE

International Headquarters

Institut Straumann AG
Peter Merian-Weg 12
CH-4002 Basel, Switzerland
Phone +41 (0)61 965 11 11
Fax +41 (0)61 965 11 01

© Institut Straumann AG, 2009. All rights reserved.

Straumann® and/or other trademarks and logos from Straumann® that are mentioned herein are the trademarks or registered trademarks of Straumann Holding AG and/or its affiliates. All rights reserved.